

The EDS All-Industry Reception:

# The Ultimate Networking Event!

Tuesday night, the atmosphere was absolutely “electronic,” as nearly 500 attendees gathered together in the Mirage Event Center to catch up with industry friends, network and mingle at our annual All-Industry Kickoff Reception. Of course, this being Las Vegas, Frank, Dino and Sammy of the “Rat Pack” dropped by to serenade us.

And, as always, the festivities concluded on a winning note with our ever-popular raffle, which featured some very cool electronics.



# SELECTION STARTS HERE



With over 2,300 name-brand, industry-leading suppliers—be confident we've got your electronic component and automation needs covered.

Find it at [digikey.com](https://www.digikey.com) today, or call 1.800.344.4539.



Digi-Key is an authorized distributor for all supplier partners. New products added daily. Digi-Key and Digi-Key Electronics are registered trademarks of Digi-Key Electronics in the U.S. and other countries. © 2022 Digi-Key Electronics, 701 Brooks Ave. South, Thief River Falls, MN 56701, USA

ECIA MEMBER  
Supporting The Authorized Channel

## EDS 2022-2023 Officers, Directors and Management

### OFFICERS

**Chris Wadsworth**  
Carlton-Bates Company  
*President*

**Chuck Tanzola**  
Fusion Sourcing Group, Inc.  
*Vice President*

**Greg Pace**  
Ohmite Ceramic Resistor Division  
*Past President*

### BOARD OF DIRECTORS

**Anthony Alberga**  
Future Electronics

**Thomas Griffin**  
Catalyst Unity Solutions

**Robert Logan**  
Kruvand Associates

**Travis Moench**  
Rohm Semiconductor

**Kristin Schuetter**  
Mouser

**Mark Shiring**  
ebm-papst

**Mike Swenson**  
Mel Foster Company

### SUPPORTING ASSOCIATIONS

**Electronic Components  
Industry Association**  
David Loftus, *CEO*

**Electronic Representatives  
Association**  
Walter E. Tobin, *CEO*

### MANAGEMENT

**Ryan Riesterer**  
*EDS Executive Vice President*

**Vicki Hagler**  
*V-Sources, Inc.*  
*Show Management*

# Game Face

By **Walter E. Tobin**, CEO and Executive Vice President, ERA



Here we all are, back at the Mirage for another EDS Summit! It is the second year in a row for in-person meetings. Our calendars are full, with early starts and breakfast meetings, crowded restaurants for lunch and late and expensive dinners. Then there's that "one and done" at the Still Bar after dinner. We go up and down the dreaded elevators – which way to go out of the elevator? Trying to be on time for every meeting is a challenge. "Sorry I am late" replaces "hello" as we walk into our meeting. "Sorry, we have to go to another meeting at the top of the hour" replaces goodbye. I hope the elevator comes quickly...

We find ourselves always behind, always late — perhaps always stressed. Are we prepared for our next meeting? Who has the latest presentation?

So why do we put ourselves through this week of stress and angst?

Because we love it!

We thrive on the adrenaline and the thrill of the hunt to sign that new manufacturer, or that new channel partner or that new manufacturers' rep. Walking (or running?) down the corridors, we see old friends as we both rush by each other. "Hey, how are you doing? It's been too long." "Sorry I can't talk, I'm late for my next meeting. See you at the Still Bar later on?" As we try to remember everyone's name, we try to not get caught peeking at his or her name badge. We think to ourselves, "How does he or she know my name, but I cannot remember his/hers?"

So many of us have been to so many EDS shows. We sometimes complain about the hours of preparation, or about all of the meetings on our calendar, or the many notes and action items taken and the follow-up after we get back home.

There are two sayings that we all need to remember as we attend the EDS Summit:

"Never confuse activity with accomplishment."

"What gets measured gets done."

Try to keep both of these sayings in your mind this week.

Try to keep your eye on the prize: to develop relationships at EDS that will help grow our companies; to find that needed technology, that needed rep or that additional channel partner; and to help us better service our customers.

All of the rest of our collateral activities are merely "trojan horses" to this end. Growing sales and better servicing the customer is what EDS is all about.

Make sure that you have your professional "game face" on as you peruse the halls and elevators, happy hours, dinners and drinks after dinner. It will all be worth it, trust me. And I hope you do not get caught peeking at the other person's name badge!

Now, excuse me as I am late for my next meeting...

*Walter E. Tobin*



## WE KEEP THINGS MOVING.

For 40 years Rochester Electronics, in partnership with over 70 leading manufacturers, has provided a continuous source of critical semiconductors. The Rochester Electronics' Semiconductor Lifecycle Solution™ keeps business moving!



 **Rochester  
Electronics®**  
[www.rocelec.com](http://www.rocelec.com)

Authorized Distribution | Licensed Manufacturing | Manufacturing Services

---

**Proud Gold Sponsors of the 2023 EDS Leadership Summit**

## TTI Breakfast kicks off Wednesday to a packed house

TTI CEO Mike Morton presented a cautiously bullish outlook despite global slowdown.

While global business is strong, some softness is predicted, but most indicators remain encouraging.

As Endries International President Michael Knight observed, recessions are natural and necessary to clear out undergrowth, allowing the economy to bounce back stronger.



Connectivity  
is the foundation of  
today's world.

We understand the **Power of the Channel.**

*creating connections for life*

**molex**



### EDS - Newsletter 2023



#### The PANCON LAT-CON 1.27 series. Compact design, full performance

Pancon GmbH, as a manufacturer of various connector - systems, has expanded its product portfolio with the series LAT-CON127. The origin of this series lies in the connectors of DIN 41612/IEC60603-2 and corresponds to half the pitch of this series, i.e. 1.27 mm. This is in response to the industry's desire to make connector designs ever smaller.

Pancon GmbH  
Kaiser-Friedrich-Promenade 4  
61348 Bad Homburg v. d. Höhe  
Germany

Phone: +49 6172 9180157  
E-Mail: [customer-service@pancon.de](mailto:customer-service@pancon.de)

Imprint | Data protection © 2022

[www.pancon-connectors.com](http://www.pancon-connectors.com)

### The LAT-CON 1.27 Benefits at a glance: Fields of application:

- small size, thus smaller pack sizes are possible
- 100 % protection against mismatching
- High precision, 0.1 mm coplanarity
- 2.5 mm contact overlap
- Two-leg contact
- Resistance to vibration and shock

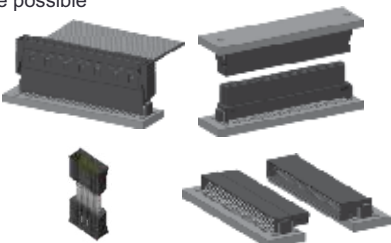

- industrial controls
- automation technology
- building services
- automotive industry
- medical technology
- consumer products



Our experienced team of experts is always at your disposal – with extensive engineering expertise for customerspecific product and process development.

The connectors of the LAT-CON127 series are available as male, female, IDC-spring and distance adapters in different heights. Very compact 90°, 180° and 360° connections as well as flexible connections can be realized with this product family. The double row series LAT-CON127 is offered as SMD version.



L to R: David Loftus, President and CEO, ECIA; Stephanie Tierney, Director of Marketing Communication and Member Engagement, ECIA; Victor Meijers, Senior Vice President, ECIA.



## Welcome EDS First Timers

If you see someone with this pink *First Time Attendee* ribbon on their badge, be sure to say high and welcome them to the EDS family

## bisco industries celebrates 50 years

bisco industries celebrates 50 years of connecting the supply chain with excellence. Headquartered in Anaheim, CA, bisco first opened on March 12, 1973 in Chicago, IL. bisco continues to be led by Founder and CEO Glen Ceiley and now has 52 locations. Their most recent opening was their first off-continent office in Manila, Philippines.



### SAVE THE DATE

October 22-24, 2023 – Loews Chicago O'Hare Hotel

[eciaexecconference.org](http://eciaexecconference.org)

### SHORT CIRCUIT

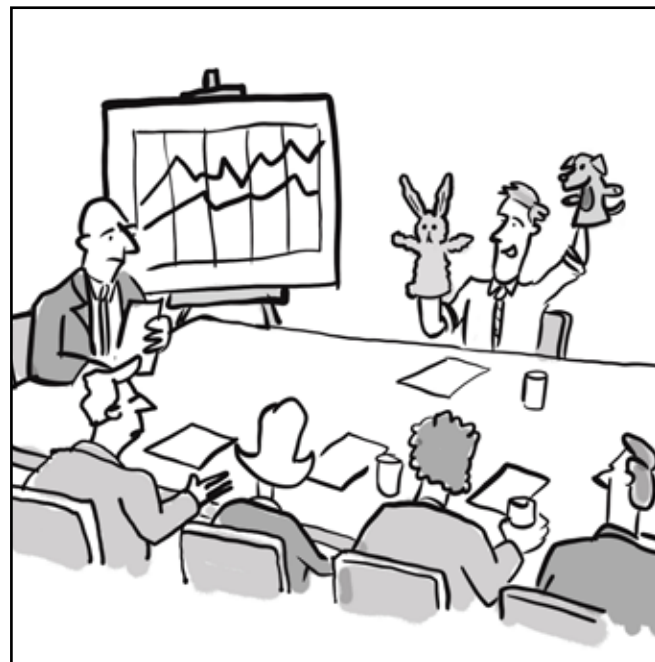

"At least it's not another PowerPoint"

WHY EDS?

## It's a Leadership Summit.

EDS brings together the industry's top talent from leading manufacturers, sales representatives and distributors to share insights, focus resources, make plans and build new business.



WHY EDS?

## Direct industry affiliation.

EDS is a combined effort and strongly supported by the industry's leading member organizations— Electronic Components Industry Association (ECIA) and Electronics Representatives Association International (ERA).







WHY EDS?

## It's an "Idea Exchange."

EDS is unique because it functions as both a high-level, meeting-based event and a vibrant marketplace of ideas for movers-and-shakers — taking place in strategic meetings, at planned events, and during informal gatherings.

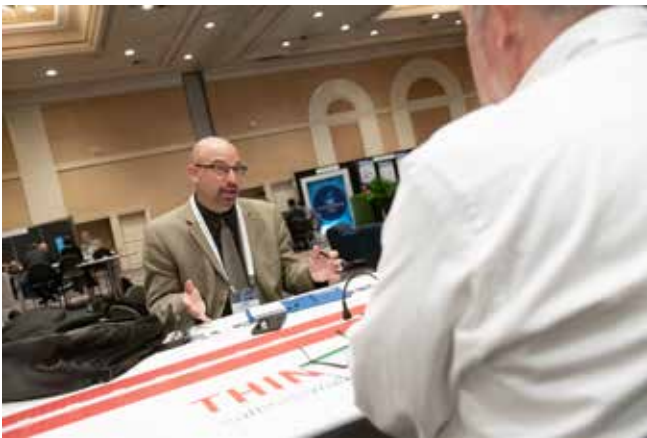

# Virtual Spark 2.0 is coming this fall!



Do you have employees who've previously participated in the Spark 1.0 Professional Development Group? Register them now for Spark 2.0!

Spark 2.0 is an advanced program focused on leadership skills and abilities to face current challenges in the electronic components industry. Your employees will gain an understanding of market demands that drive the creation of innovative technology products and services. This program provides insight into the changes in the external environment and the health of the industry. Slots are extremely limited. Spark 2.0 is currently in development. For registration information and scheduling, contact Jennifer Smith at [jennifer.smith@jmssynergy.com](mailto:jennifer.smith@jmssynergy.com).

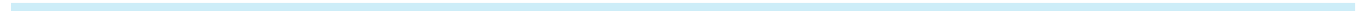

## All of EDS at your fingertips.

### USE THE EDS WEB APP

- See who's here
- Mirage maps and info
- Official EDS 2023 schedule
- News and updates from EDS
- View the Summit Daily

Just visit [edssummit.com](http://edssummit.com) on your phone during the summit, and be sure to save it to your home screen for easy access.

Scan to access



# Making An Impact Through Today's Supply Chain Challenges

Waldom Electronics, known as “The Distributor’s Distributor!”, of both electronic components and solutions, has had an exceptional year of growth under the guidance of their new CEO, Don Akery. Despite facing strong market headwinds and challenging industry conditions, the company has achieved significant accomplishments and positioned itself for continued success in the years to come.

One of several key accomplishments of Waldom Electronics this past year has been the expansion of its world-class Manufacturing Line Card. CEO Don Akery recognized this potential for growth in passive and power components successfully driving the company into these new territories. By expanding their already impressive IP&E product portfolio, Waldom has been able to tap into new distribution partners and diversify their offering with the global distributors, which has strengthened their position as a key supply chain partner for their manufacturer’s channel ecosystems.

through today. Further, historical research conducted by multiple manufacturers, distributors and other organizations has shown that restricting the sales viability of electronic components, solely due to age, can unnecessarily result in disruptions within the supply chain. The extended warranty has been determined a significant benefit to both manufacturer and distributor partner operations.

Overall, Waldom Electronics has experienced an exceptional year of growth and accomplishments under the leadership of CEO Don Akery. As market conditions have changed the outlook and landscape of inventory profiles, Waldom stands committed to expanding inventory depth and width complimentary to the channels existing core and strategic part numbers. Waldom expects its inventory position to grow by 25% to over \$500M in 2023 as they continue to provide solutions assisting manufacturers and distributors overcome challenges of slow-moving and excess inventory.



“Waldom continues to make great progress in providing immediate availability on difficult-to-stock items for distributors. This helps distributors deliver more products to their customers without the risk of excess inventory!”

— Don Akery, Global CEO – Waldom Electronics

Additional accomplishments where Waldom Electronics has excelled this year is in the continuation and expansion of integrated inventory feeds with their global distribution partners. Waldom has been focused on delivering it’s growing 215,000 plus non-strategic products directly into distributors’ ERP and digital platforms. This has resulted in successfully expanding their SKU count offering to their customers by allowing them to invest deeper and wider with manufacturer’s core products.

Distributors can “Purchase with Confidence” through Waldom’s increased warranty period for defective and/or out-of-spec product(s) to Twenty-Four (24) months. Waldom’s strict receiving procedures for Slow-Moving and Excess (SM&E) inventory have resulted in an industry leading performance in both product and shipment quality. This performance has steadily improved from the inception of Waldom’s Stock Recovery program in the early 2010’s

Waldom Electronics continues it’s 75-year legacy of being a trusted partner and Master Distributor of both electronic and electrical components, selling exclusively to distributors, never to OEMs or end-users.

Partnering with over 40 premier brand manufacturers offering 215,000 parts in stock, available at reduced MOQs, Waldom is today’s problem solver to supply chain disruptions. Learn more: [waldom.com/about](http://waldom.com/about).



**WALDOM ELECTRONICS.**



# Solutions for Original Equipment Manufacturers (OEMs)

We build, connect, power and protect applications for environments around the world.

Optimizing your organization is essential for continued success. OEMs need practical, solutions-oriented supply chain partners that work without hesitation; doing whatever it takes to create the smartest path forward for business challenges big and small.



## Ingenuity delivered.

[Wesco.com](https://www.wesco.com)

230284A001 © 2023 Wesco International



ERA CEO Walter Tobin and Director of Communications Clare Kluck demonstrate the new SearchLink.ai interface in the ERA Business Center.

## ERA launches SearchLink.ai

ERA SearchLink.ai is an online search tool specifically designed for the electronics industry.

SearchLink.ai is a search engine overlay that will help ERA members identify the right prospect opportunities, engineers, decision-makers, job seekers, industry news and more — quicker than they would be able to do on their own.

“Our members are looking for new ways to reach customers. This tool provides an innovative way to perform highly-focused customer searches that give tailored results. We are so excited about this new tool and invite you all to check it out,” said Walter Tobin, CEO of ERA.

### SHORT CIRCUIT



"I don't care. Next year, we're getting the bigger suite."

Stay Connected.  
Be Involved.  
Make an Impact.



Visit the ERA Business & Hospitality Center located in the Mirage Grand Ballroom, Booth #102.

Use the Business Center as your EDS headquarters for small meetings, networking and coffee breaks.

Interested in learning about the many benefits of being an ERA member? Come chat with the ERA staff!

**Ask us about the new ERA SearchLink.ai tool and STEP training this fall!**



The force behind reps, manufacturers and distributors in the electronics industry.

**Join ERA today at [era.org](http://era.org).**

# YAGEO

## Group

Welcome to what's next!

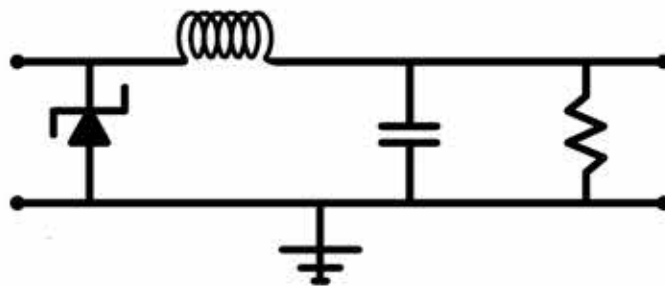



Zeus Battery Products presents its Impact Player and Difference Maker awards to Master Electronics.

L to R: Cyndi Hullett, Master Electronics; Shell Johnson, Master Electronics; Peter Garvey, Zeus Battery Products; Johnathan Parker, OnlineComponents.com; Gina Galante, Zeus Battery Products.

**75%**  
of businesses say  
their website is  
extremely important.\*

Source: HubSpot

**100%**  
of those websites  
could be improved.

## How confident are you in your digital marketing effort?

- Web Performance Optimization
- Web Design & Development
- Mobile-First Approach
- Search Engine Optimization
- Search Engine Marketing
- Analytics & Reporting
- Branding & Positioning
- Content Strategy
- Advertising
- Video
- Direct Response

Specializing in the industrial and electronic component industries. Stop by and see us in Connections Café.

[dhdchicago.com](http://dhdchicago.com)



DAVIS  
HARRISON  
DION

STRATEGIC COMMUNICATIONS

**EMPOWERING INNOVATION  
TOGETHER™**

# Powering a greener tomorrow with green energy storage systems.

Mouser Electronics® Empowering Innovation Together™ explores the growing divide between green energy capture and grid storage while exploring the innovative technologies helping to close the gap.

*Listen to the podcast, see the videos, read expert articles and more at:*

[mouser.com/empowering-innovation](https://mouser.com/empowering-innovation)





# Grab food on the go at the Connections Café

Grab-and-go breakfast, lunch and coffee will be available Thursday from 7 am to 3 pm.



Your Premier Source for  
Electronic Components  
& Specialty Fasteners.



US: 800.323.1232  
Canada: 800.258.2693

[www.biscoind.com](http://www.biscoind.com)  
[info@biscoind.com](mailto:info@biscoind.com)

Stay connected:    

**bisco industries®**  
CONNECTING YOUR SUPPLY CHAIN WITH EXCELLENCE

# A low-tech success

Manufacturers, distributors and reps looking to develop new business relationships at EDS 2024 can get a head start at the new EDS Matchmaking board in the Connections Café. Just pin your business card and a brief description of what you're looking for to the board, It's an easy way to make new connections.



Zhihai Yu of Ningbo Kepo Electronics posts his information on the EDS Matchmaking board.



TDK-Lambda presents an award to Master Electronics. L to R: Melissa Guerrero, TDK-Lambda Americas; Cyndi Hullett, Master Electronics; Mark Teo, TDK-Lambda Americas; Todd Jesme, Master Electronics; Michael Khoshaba, Master Electronics.



**TrustedParts.com**

We verify distributors are authorized.

- ✓ Proof of authorization required for each region
- ✓ Regular audits to verify authorization status

**100% AUTHORIZED SOURCES**

Search authorized distributors at [TrustedParts.com](https://www.TrustedParts.com)

# Thank you EDS Sponsors

## PLATINUM SPONSOR



## GOLD SPONSORS



the TTI FAMILY  
of SPECIALISTS



## SILVER SPONSORS



## BRONZE SPONSORS



## SERVICE PROVIDER SPONSORS



# Every ten seconds, Supplyframe reaches more electronics professionals than any other network on the planet.

Can you keep up with the demand?

Demand Index  
**33.92% ↑**  
Year-to-year

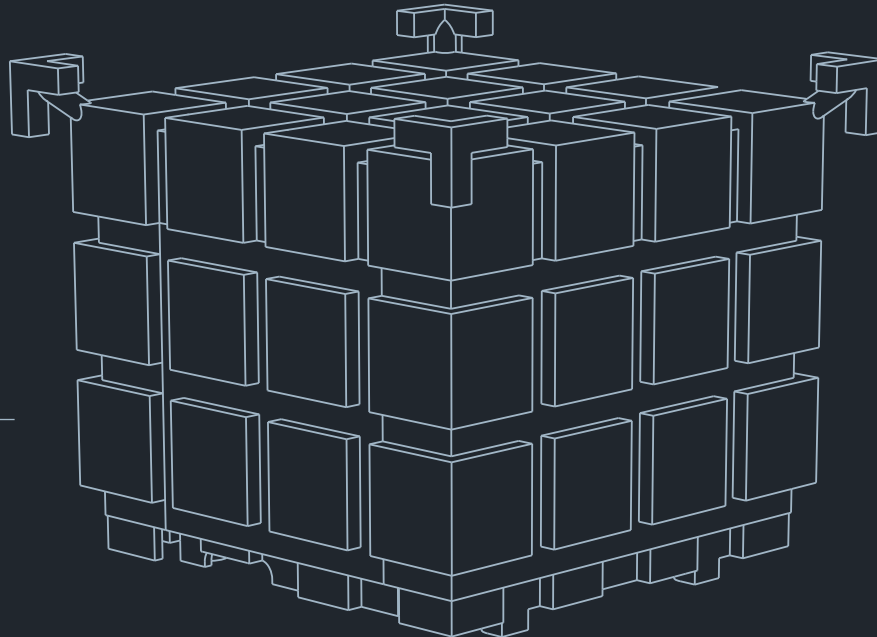

Lead Time  
**30 weeks ▼**

Life Cycle  
**Active**

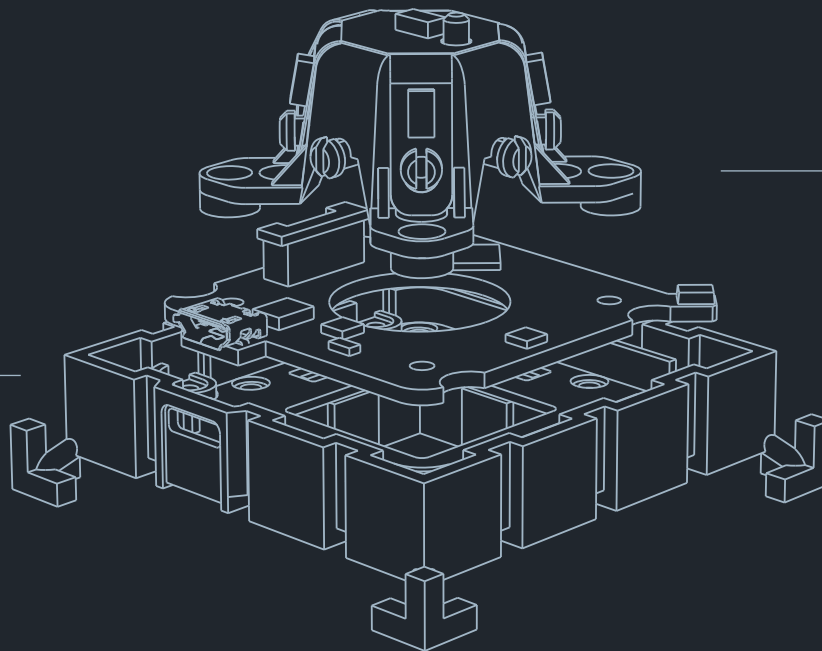

Design-to-Source Intelligence

Always on. Always learning. Always improving.



Find out more about Supplyframe's intelligent marketing solutions to anticipate, respond and gain more design wins today.